

# DP E12.UART

---



## CONTENT

---

|                          |   |                             |   |
|--------------------------|---|-----------------------------|---|
| Content.....             | 1 | Normal indication area..... | 6 |
| Introduction.....        | 2 | Button definition.....      | 7 |
| Overview drawing.....    | 3 | Normal operation.....       | 7 |
| Specifications.....      | 4 | Error code definition.....  | 8 |
| Functional overview..... | 5 |                             |   |

# INTRODUCTION

- Name: Intelligent display
- Model: DP E12.UART
- Scope: EN15194 electrically power assistance cycle
- Appearance:



- Numbering on the back of the display  
Numbers are divided into two lines (as shown in the figure):

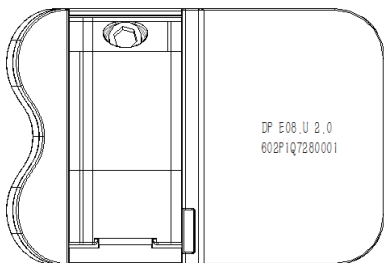

- A. Up row number (as below)

DP E12.U 2.0

- ① DP E12.U : BAFANG display model
- ② 2.0: hardware version number

- B. Down row number (as below)

602F8Q7280001

- ① 602: Wire length and connector model  
850 M5.2
- ② F8: number of test device
- ③ Q7280001: Production date is  
July 28th,2016; SN is 0001

- Display P type wire label number rule

Number on the middle of P type label, number is divided into up row and down row and QR code is at right side (as shown in the below figure)

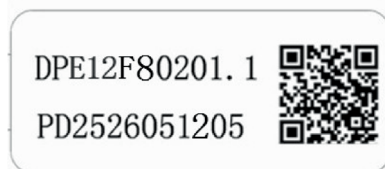

- Content of QR code:

DPE12F80201.1

PD2526051205

DP E12.U 2.0

602F8Q7280001

- The first line:

DPE12F80201.1 - Software version

- The second line:

PD2526051205 - Parameter code

- The last two lines:

DP E12.U 2.0 / 602F8Q7280001 - SN

# OVERVIEW DRAWING

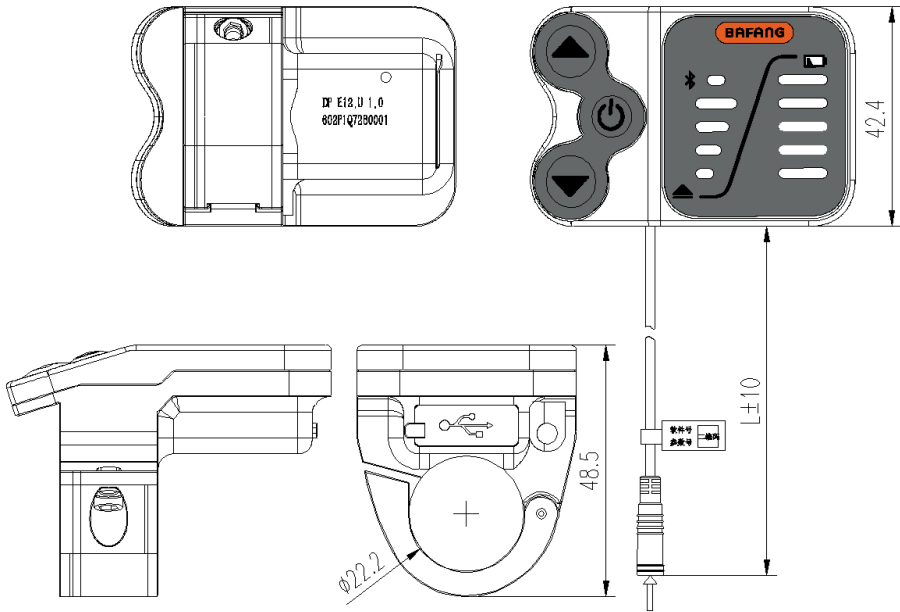

Housing material is ABS, decal material is PC with UV-Resistance.

# SPECIFICATIONS

---

- Rated voltage: 36V/43V/48V DC
- Rated current: 35mA lines(as shown in the figure)
- Maximum working current: 35mA
- When power off, leak current is less than: 1uA
- Working current supplied to controller: 50mA
- Operation temperature: -20 °C~45 °C
- Storage temperature: -30 °C~70 °C
- IP level: IP65
- Storage humidity: 30%-70%

# FUNCTIONAL OVERVIEW

---

- Using the bidirectional serial communication protocol and the three-key keypad enables users to operate the display with ease.
- Intelligent battery level indication: thanks to an optimization algorithm, a stable display of the battery level is ensured, and the problem of fluctuating battery level indications common to most displays is avoided.
- Lamp automatic control: automatic turn on/off front and back lamps, when outside light changes.
- Display LED second level automatic adjustment: according to the change of outside light, adjust LED display luminance automatically, that solve the problem of dazzling display at night and indistinct display under the strong light common to most LED display in the market.
- PAS level control: 0/1/2/3/4/5
- Error code prompt
- Walk assistance
- Set parameters: via communication cable, may set parameters in PC including wheel diameter, speed limit and so on, please see specific parameter set description document.
- If no use within 5 minutes, system turn off automatically.
- USB port can provide power to external device and display support Bluetooth function.

# NORMAL INDICATION AREA

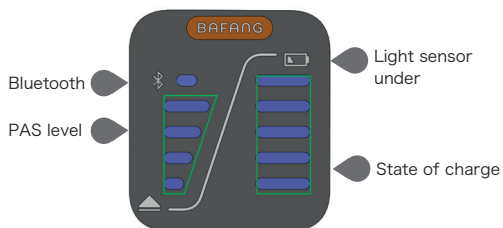

- State of charge indication: 5 LED display the state of charge, if the lowest LED flickers, it means the time to charge the battery.

| LED indication definition<br>(from down to up) | SOC     |
|------------------------------------------------|---------|
| 5                                              | >75%    |
| 4                                              | 50%-75% |
| 3                                              | 30%-50% |
| 2                                              | 10%-30% |
| 1                                              | <10%    |
| 1 Flickers                                     | ≤5%     |



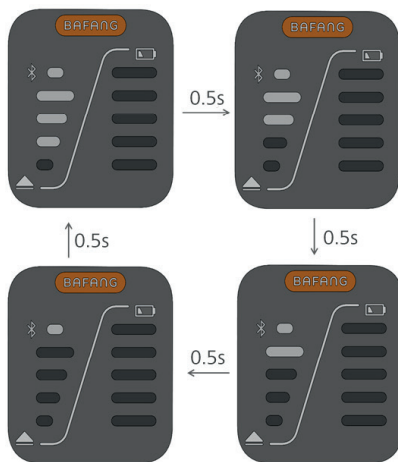



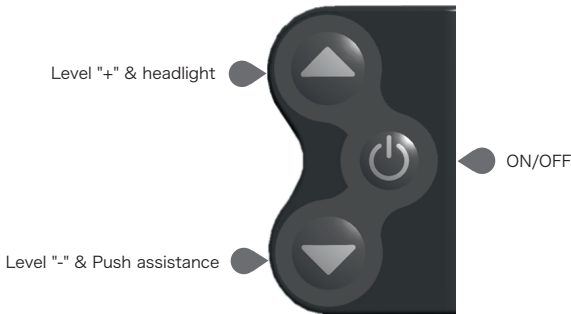

- PAS level indication: display current PAS level 0-4; if no LED display, it means it is level 0; 1-4 is in accordance with the PAS level. In the mode of Push Assistance, LED loop light one by one from down to up with 0.5s time interval (as shown in the below figure)



# BUTTON DEFINITION



## NORMAL OPERATION

- Power on/off
  - press  for 2s, the display will turn ON;
  - press  for 2s, the display will turn OFF. It will automatically turn OFF when standby in 5 minutes.
- PAS level selection
  - Press  or  to switch between the different support levels (0 / 1 / 2 / 3 / 4 / 5); Lowest level and the default level is 1; Highest level is 5; when no LED light, it is level 0 (mean park level).
- Lamp/LED display luminance
  - Press  for 2s, LED display turn dim, then turn on the front lamp and rear lamp at the same time. Again press  for 2s, LED display highlight, meanwhile turn off front light and rear light. (if fail to manipulate the lamps manually , need to restart the LED HMI and then lamps can restore automatically)
- Walk-assistance selection
  - Press  for 2 seconds, the walk assistance will be turned ON, and level LED flicker, If you move your finger away from this button, the walk-assistance will be turned OFF.
- Blue tooth connection
  - After the blue tooth is connected, the LED at the right of bluetooth  begin flicker.

# ERROR CODE DEFINITION

**i** This system can indicate all errors occurring on the Pedelec. In certain modes, the LEDs will flicker when an error code occurs.

| Error code                                                       | Error definition                                          | Solution                                                                                                                                        |
|------------------------------------------------------------------|-----------------------------------------------------------|-------------------------------------------------------------------------------------------------------------------------------------------------|
| The second LED flickers 7 times in rapid succession              | High voltage protection                                   | Check the battery voltage                                                                                                                       |
| The second LED flickers 8 times in rapid succession              | Fault with motor hall sensor inside                       | Have your dealer check the motor stator                                                                                                         |
| The first LED flickers once                                      | The motor temperature reaches to the max protection value | Stop riding and wait until the LED stop flickering                                                                                              |
| The first LED flickers once then the second LED flickers twice   | Fault with current sensor inside controller               | Have your dealer check the controller                                                                                                           |
| The first LED flickers once then the second LED flickers 3 times | Fault with temperature sensor inside battery              | Check the battery                                                                                                                               |
| The first LED flickers twice then the second LED flickers once   | Fault with wheel speed detecting sensor                   | Check the motor stator                                                                                                                          |
| The first LED flickers twice then the second LED flickers twice  | BMS communication fault                                   | Replace the battery                                                                                                                             |
| The first LED flickers 3 times in rapid succession               | Communication fault                                       | <ol style="list-style-type: none"><li>1. Check the connectors between the EB-BUS and the controller</li><li>2. Replace the controller</li></ol> |





# NOTES

---



# NOTES

---